

Copyright © 2007, QVF Engineering GmbH. All rights reserved.



COLUMNS FOR PACKINGS

To ensure the scale-up-capability of a separating column in the Miniplant scale, it is important to limit the uncontrolled reflux in order to distil in a quasi-adiabatic way.

For this purpose, the columns, up to 150°C, are equipped with an evacuated (10^{-6} millibar) isolating jacket, which is silver-coated on the inside and extends to the flat safety flange. At higher temperatures, an additional isolating or an adiabatic auxiliary heating is useful. If heating, it must be controlled in a way that the jacket temperature and the column temperature differ from each other by less than 0.2°C. To compensate for the different thermal expansions between the inner and outer tubes, these isolating jackets are equipped with one, two or three expansion bellows, depending on their lengths. An inspection slot in the silver-plating allows observation of the processes in the column. There are three different ways of placing the bulk material or packings. If the liquid will be collected between the columns and then redistributed from the central collecting point, the version with assembly baskets is recommended. If the LB assembly frames are used, guide funnels should be used to avoid run-out on the edges. If additional measurement outlets are required between the segments, the universal intermediate bottom with inlaid assembly frame is applied.

 The design of funnels and assembly frames requires a minimum size for the packing. If process technology reasons require going below this size, a packing of larger size must first be placed in the column.

In the following table you find further details on this and on the free cross sections of the individual component parts, which are important for the layout of columns. Please note the difference between the nominal diameter DN (nominal mating diameter for the connection) and the inner diameter D1.

	Free cross section			Packing		
	Packing support M-PF	Packing support LB LBE		Minimum size of packing M-PF LB LBE		
DN ¹⁾	%	%	%	mm	mm	mm
30	76	-	-	8	-	-
50	72	84	-	10	10	-
80	60	73	59	15	10	10

¹⁾ Corresponds D1 for jacketed column section

COLUMN WITH ISOLATING JACKET

The columns M-ICS don't have a support bead for the placement of baskets or assembly frames. They are used in conjunction with a universal adapter or for the extension of columns which have a support.

DN	D	DN1	DN2	L	Bellows	Type	Reference
50/30	75	30	50	650	1	A	M-ICS50/30/500
50/30	75	30	50	1160	2	A	M-ICS50/30/1000
80/50	90	50	80	510	1	B	M-ICS80/50/500
80/50	90	50	80	1020	2	B	M-ICS80/50/1000
100/80	120	100	100	510	1	B	M-ICS100/80/500
100/80	120	100	100	1020	2	B	M-ICS100/80/1000

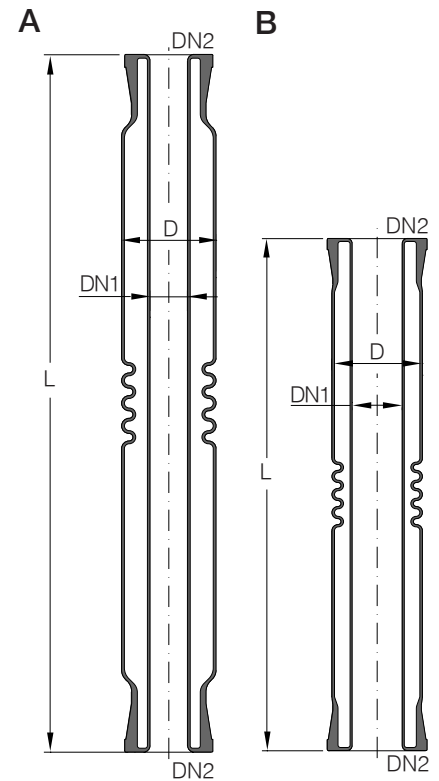

COLUMN WITH ISOLATING JACKET AND SUPPORT RING

Each column is equipped with a measurement outlet underneath the support ring. While the basket is fused in for nominal diameter DN 50 (inner diameter 34 mm), for the larger nominal diameters an LB assembly frame can be used as an alternative. Like the basket, this assembly frame is not included in the scope of delivery. If a packing is to be used, the free cross section of the basket is sufficient. If the guiding funnel behavior of the basket is not desired, the ordered packing can be set directly on the support ring, using an intermediate ring of PTFE.

DN	D	DN1	DN2	GL1	L	L1	Bellows	Type	Reference
50/30	75	30	50	18	650	120	1	A	M-ICST50/30/500
50/30	75	30	50	18	1160	120	2	A	M-ICST50/30/1000
80/50	90	50	80	18	650	110	1	B	M-ICST80/50/500
80/50	90	50	80	18	1160	110	2	B	M-ICST80/50/1000
100/80	120	80	100	18	650	130	1	B	M-ICST100/80/500
100/80	120	80	100	18	1160	130	2	B	M-ICST100/80/1000

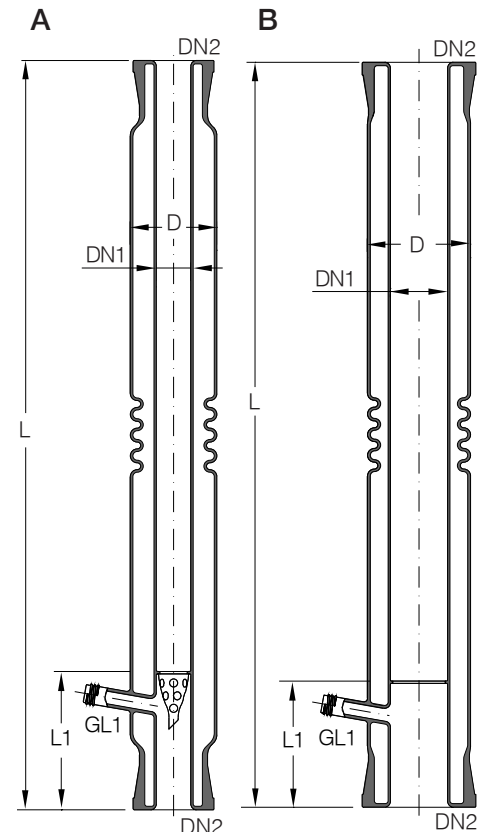

PACKING SUPPORTS

Using these basket supports ensures that the liquid is placed in the center of the subsequent column, as is desired for small column diameters.

Their free cross section was chosen such that it is sufficiently wide for the application of ordered packings as well. The support baskets are placed in the columns, together with an intermediate ring of PTFE, in order to avoid glass-to-glass-contact. The intermediate rings are included in the scope of delivery of each support basket.

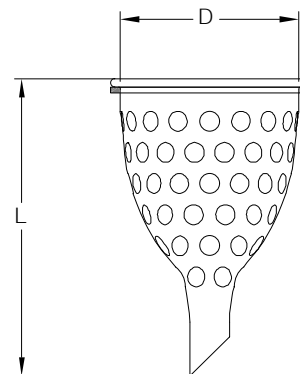

For DN	D	L	Reference
50	26	50	M-PF30
80	44	75	M-PF50
100	63	105	M-PF80

RANDOM PACKING

In addition to the Rasching rings listed here, which are made of 3.3 borosilicate glass, we also provide packings made from other materials, which are adapted to the application and have different geometries. We will be glad to make the right selection and design the column for you.

You can find other sizes of Rasching rings made of 3.3 borosilicate glass in the WPR 2002 Catalogue.

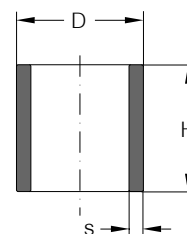

D x H	S mm	Bulk density random kg/m ³	Surface random kg/m ³	Reference
3 x 3	0,6	996	1547	FC3
6 x 6	0,5	496	860	FC6

GUIDING FUNNELS FOR COLUMNS WITH INSULATION JACKET

Guiding funnels are clamped into the standard flange connection, i.e. they simultaneously act as ring seals. During the column filling process, care must be taken to keep the necessary distance between the packing and the bottom edge of the guiding funnel.

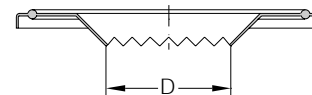

DN	D	A free %	Reference
50/30	20	51	M-ITL50/30
80/50	35	49	M-ITL80/50
100/80	55	47	M-ITL100/80

PACKING RETAINERS

These component parts are used, for example, at the column head to prevent potential damage of reflux heads or condensers possibly arising from torn packings. They cannot be used as packing supports.

The packing retainers consist of a PTFE ring, which is stringed with a tantalum wire. They are clamped between the glass component parts instead of a PTFE ring seal, using a standard clip connection. Version A is used for component parts without isolating jacket, whereas version B fits the insulated components.

DN	D	A free %	Type	Reference
50	45	81	A	M-CPC50
80	67	76	A	M-CPC80
100	98	87	A	M-CPC100
50/30	25	88	B	M-ICPC50/30
80/50	45	98	B	M-ICPC80/50
100/80	67	100	B	M-ICPC100/80

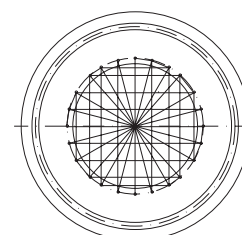
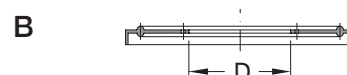
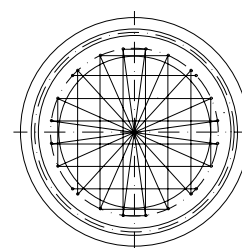
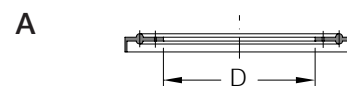

PACKING SUPPORTS

The packing supports are suitable for columns with support bead and the universal adapter (see below). For technical data, such as free cross section and minimum size of packings, please refer to the introductory section of this chapter. For the nominal diameter DN 50, the distance between the support bars was chosen larger than the reasonable packing size in order to keep the free cross section sufficiently wide.

☞ For isolating jacket components, use the next smaller nominal width instead of the nominal connection width.

DN	D	L	E	Reference
50	48	12	8	LB50
80	70	20	7	LB80
100	95	20	7	LB100

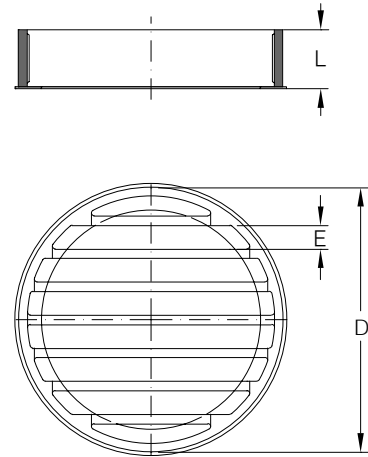

BUBBLE CAP COLUMN

Bubble cap columns meet the requirements for high and constant effectiveness over a broad load range. They have good guidance for vapor and liquids and a relatively low pressure loss. The specific advantage of a bubble cap column is that the equilibrium state (concentration profile), once established, is largely conserved, even if the process is interrupted, so that equilibrium is re-established within a short time after a restart.

Measurements have revealed that with the test mixture chlorobenzene / ethyl benzene the effectiveness per bottom range from 0.5 to 0.8 at normal pressure and from 0.7 to 0.9 at 66 millibar. The F-factor range was measured from 1.0 to 0.1 Pa 0.5.

The influx and drain of the bottom are separated by a fused in glass weir, so that the liquid is guided in a circle. Each bottom has a stack. The last liquid drain is equipped with a siphon.

Standard bubble cap columns are available either with a silver-coated, evacuated (10^{-7} millibar) isolating jacket, which extends to the flat safety flange, or without an isolating jacket. An inspection slot in the silver coating allows the observation of the processes in the column. All bubble cap columns are equipped with either 5 or 10 practical fused-in bottoms.

Between the lower bubble cap bottom and the flat safety flange, there is an outlet for insertion of a measurement element. The adjacent picture shows special constructions.

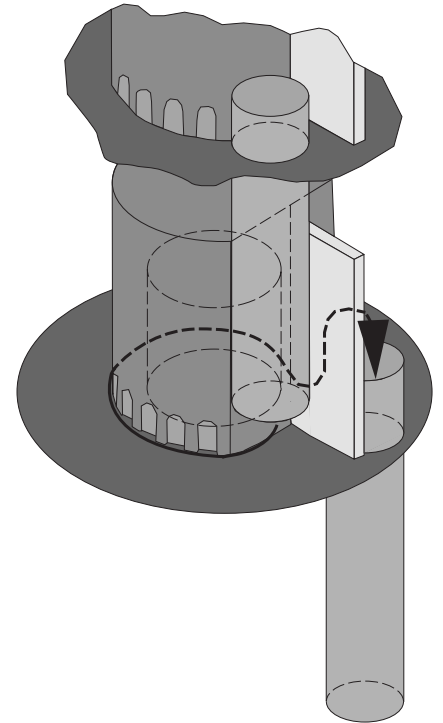

BUBBLE CAP COLUMN

DN	GL1	L	Plates	Reference
50	18	500	5	M-BCT50/5
50	18	750	10	M-BCT50/10
80	18	640	5	M-BCT80/5
80	18	1000	10	M-BCT80/10

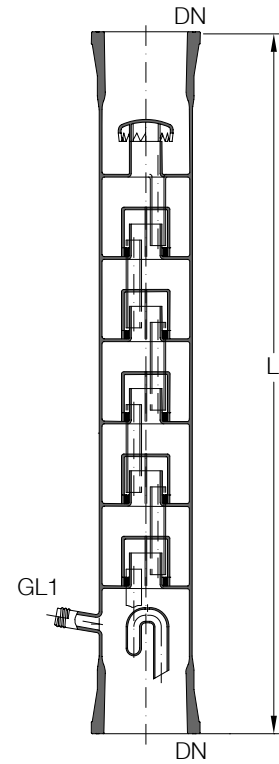

BUBBLE CAP COLUMN

DN	D	DN1	DN2	GL1	L	Plates	Bellows	Type	Reference
50/30	75	30	50	18	440	5	1	A	M-IBCT50/30/5
50/30	75	30	50	18	620	10	1	A	M-IBCT50/30/10
50/50	90	50	50	18	540	5	1	B	M-IBCT50/50/5
50/50	90	50	50	18	800	10	1	B	M-IBCT50/50/10
80/80	130	80	80	18	705	5	1	B	M-IBCT80/80/5
80/80	130	80	80	18	1080	10	2	B	M-IBCT80/80/10

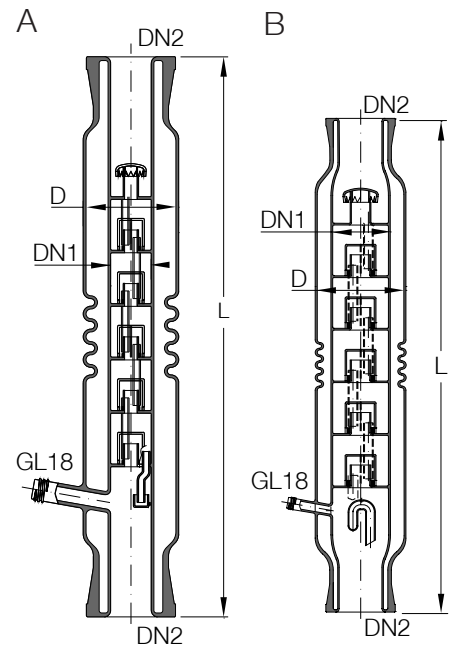

REFLUX SEPARATOR, ELECTROMAGNETICALLY ACTUATED

If it is desired to establish the reflux ratios in a precise and reproducible way, the use of an electromagnetically actuated liquid separator in conjunction with a timer is recommended.

In this version, the movable funnel, which is movably supported and has a fused-in counter-magnet, is attracted (total drain) or repelled (total reflux) by a magnet, which is attached to the outside of the column and can be switched over by means of the timer. In order to ensure a faultless function of the liquid separator, the funnel should stay in one of its end positions for not less than 2 seconds.

For electromagnetically actuated liquid separators, a liquid seal is always necessary to prevent vapor from entering the distillation line. The electromagnet and the timer have to be ordered separately. You can find the nominal diameters DN80 and DN100 in the WPR 2002 catalogue.

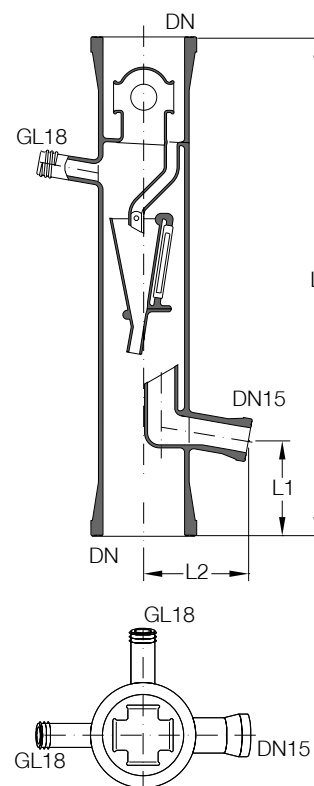

DN	L	L1	L2	Reference
50	330	63	70	M-RHM50

REFLUX SEPARATORS WITH ISOLATING JACKET

Optionally, electromagnetically actuated liquid separators are available with silver-coated high-vacuum isolating jackets (10^{-7} millibar).

The electromagnet and timer must be ordered separately.

DN	DN1	DN2	L	L1	L2	Type	Reference
50/50	50	50	450	113	85	A	M-IRHM50/50
80/50	50	80	330	68	85	B	M-IRHM80/50
100/80	80	100	380	83	100	B	M-IRHM100/80

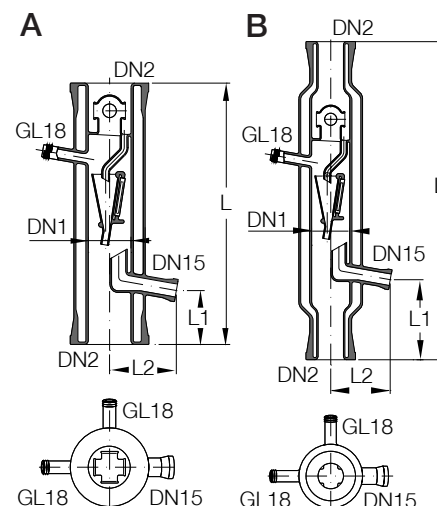

ACCESSORIES

Electromagnet (A)

In conjunction with a timer, it is used for actuating the movably supported funnels of liquid separators. Its operating voltage is 24 Volt DC.

Item	Reference
Electromagnet	M-IRHM-2

Connection cable (B)

Cables in five different lengths are available as standard for electrical connection of the above electromagnet. They are appropriate for the listed electromagnets and can be used to connect a timer.

Length (m)	Reference
2	M-IRHM-3/2
4	M-IRHM-3/4
6	M-IRHM-3/6
8	M-IRHM-3/8
10	M-IRHM-3/10

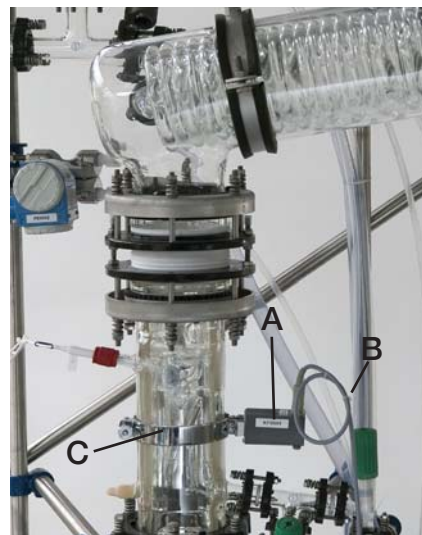

Suspension device (C)

Like the electromagnet, these suspension devices are used in electromagnetically controlled liquid separators.

 These clamps are used to attach the electromagnet to the liquid separator. You can refer to the following table for the size (= reference number).

For reflux separator	Ø	Reference
M-RHM50	60	M-RHM50-3
M-IRHM50/50	90	M-IRHM50/50-3
M-IRHM100/80	120	M-IRHM100/80-3

REFLUX SEPARATOR, MANUALLY ACTUATED

The reflux is adjusted by means of a valve to be mounted on the drain outlet. If the valve is completely opened, the head is set to total drainage of the distillate, because the reflux tube is placed higher than the drain outlet. Through proper throttling of the valve, the reflux ratio can be adjusted continuously until a total reflux is reached.

The reflux ratio is not clearly defined.

You will find the nominal diameters DN80 and DN100 in the WPR 2002 Catalogue.

DN	L	L1	L2	Reference
50	200	103	69	M-RDA50

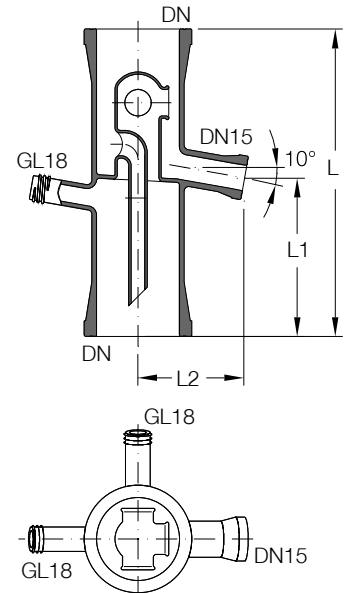

REFLUX SEPARATOR WITH ISOLATING JACKET, MANUALLY ACTUATED

DN	DN1	DN2	L	L1	L2	Reference
50/30	30	50	170	89	69	M-IRDA50/30
80/50	50	80	200	105	85	M-IRDA80/50
100/80	80	100	220	115	100	M-IRDA100/80

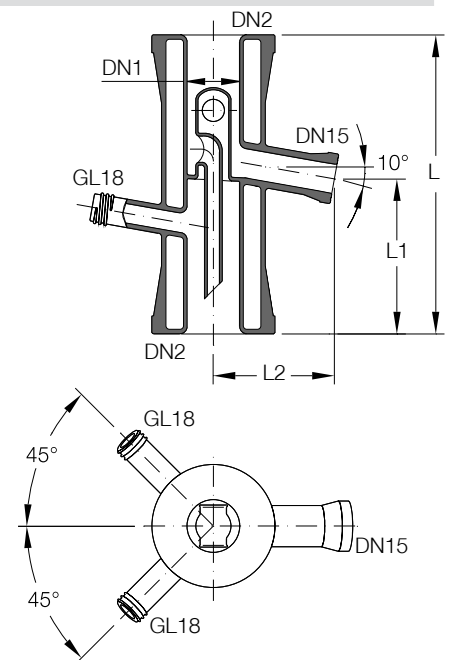

LIQUID SEAL

For electromagnetically actuated liquid separators, a liquid seal is necessary to prevent vapor from entering the distillation line.

DN	L	L1	Reference
15	158	100	M-LS15

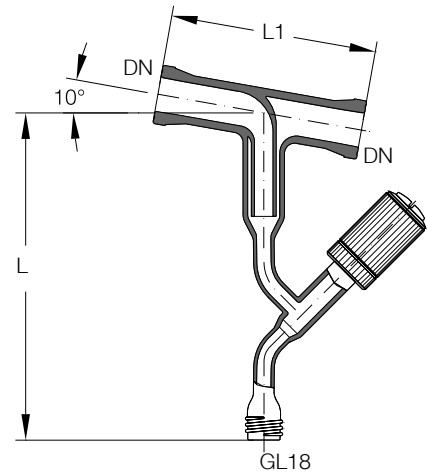

LIQUID SEAL WITH ISOLATING JACKET

For electromagnetically actuated liquid separators, a liquid seal is necessary to prevent vapor from entering the distillation line.

DN	L	L1	Reference
15	220	150	M-TLS15

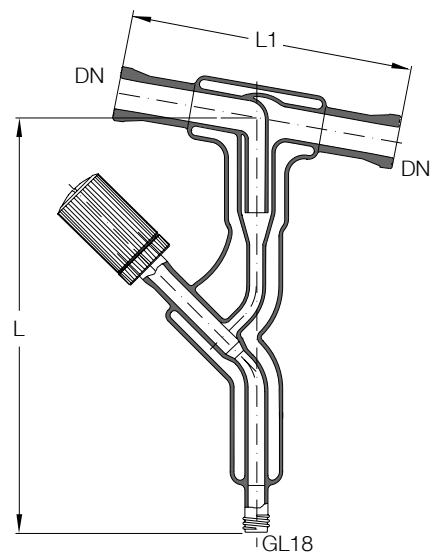

ADAPTER FOR REFLUX MEASUREMENT

The reflux quantity is determined by damming up the liquid between two check marks (equaling 10 milliliters) and performing a time measurement. This measurement method is only recommended for small column diameters or small liquid quantities.

DN	L	Reference
50	175	M-RM50
80	190	M-RM80

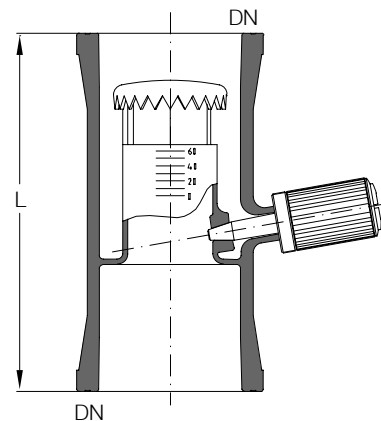

ADAPTER FOR REFLUX MEASUREMENT WITH ISOLATING JACKET

For the reflux measurement adapter with silver-coated isolating jacket, the check mark can be observed through the inspection slot.

DN	DN1	DN2	L	Type	Reference
50/50	50	50	250	A	M-IRM50/50
80/50	50	80	190	B	M-IRM80/50
100/80	80	100	200	B	M-IRM100/80

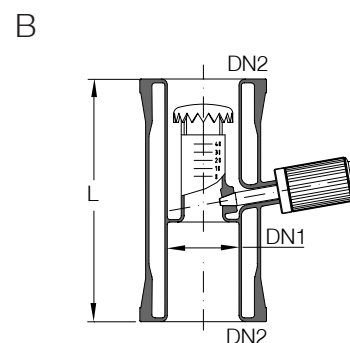
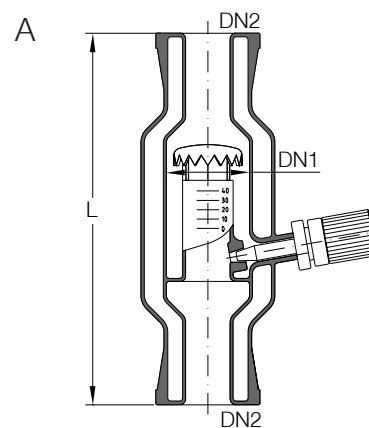

COLUMN FEED SECTION WITH RING SPRINKLERS

The use of ring sprinklers, from the nominal diameter DN 80 on, allows well distributed fluid placement, as is desired for packings and packing columns.

DN	D	L	L1	L2	Hole Ø	Hole-number	Type	Reference
80	-	225	110	110	1,5	15	A	M-FR80
100	80	225	110	120	1,5	15	B	M-IFR100/80

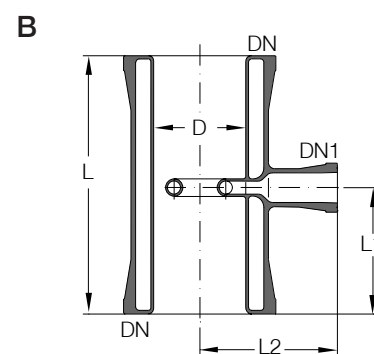
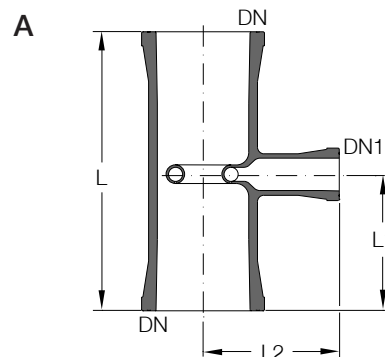

UNIVERSAL ADAPTER

Components of this type can take over various functions. And so they are available with different accessories on request. The universal adapter can be used to feed in the mixture to be separated at the column head or between the column stripper and the concentrating column, for extracting samples from the column, or for measuring process parameters.

When the LB assembly frame is inserted, they carry the packing bulk material, whereas packings can be put directly on the bearing pins.

They are available standard either with a silver-coated high-vacuum jacket (10^{-7} millibar) and inspection slot or without isolating jacket. Both types are clamped between two glass components.

DN	GL	L	Reference
50	18	75	M-FB50
80	25	125	M-FB80
100	25	125	M-FB100

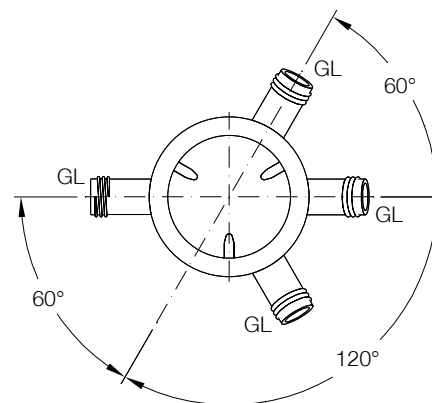
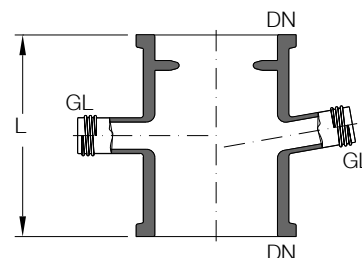

UNIVERSAL ADAPTER WITH ISOLATING JACKET

DN	DN1	DN2	GL	L	Reference
50/30	30	50	18	75	M-IFB50/30
80/50	50	80	25	125	M-IFB80/50
100/80	80	100	25	130	M-IFB100/80

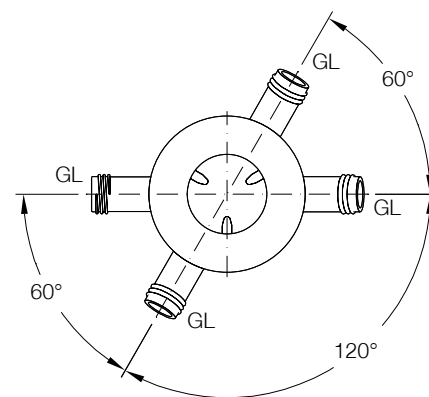
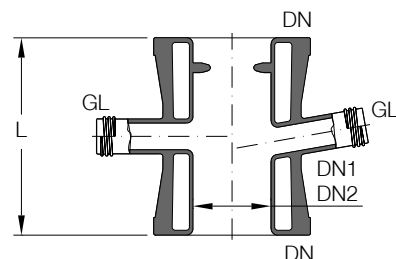

SAMPLE VALVE

The sample valve is used to extract samples from the column, preferably in conjunction with the universal adapter.

DN	L	D	Reference
50	200	10	M-ISS50-2

