

QVF®-MAGNETICALLY-COUPLED STIRRER DRIVE TYPE RAM P166.e1

- Transmitted torque up to 60 Nm
- Low-noise operation
- Hermetically sealed
- No product contamination
- No sealing liquid required

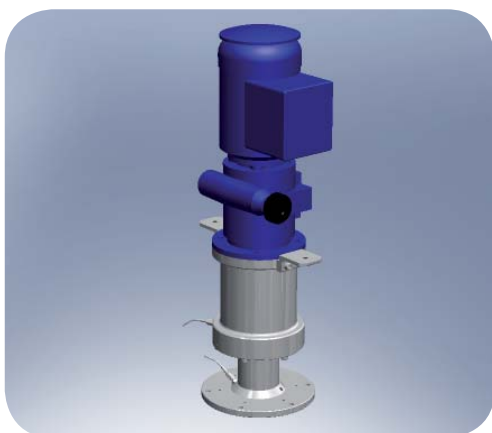

Fig. 1: Magnetically coupled QVF® stirrer with drive

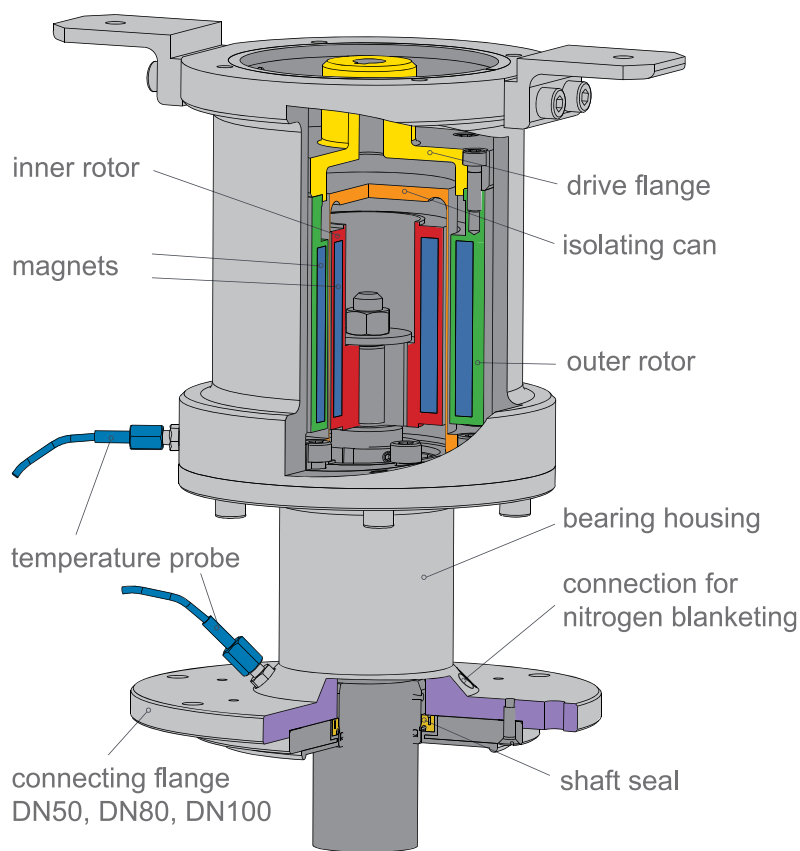

Fig. 2: Design of the magnetically coupled QVF® stirrer RAM50/80/100-3

Whether using a shaft seal or mechanical seal, there is always a possibility that substances from the process side can escape into the surroundings or the process side can be contaminated, for example from the sealing liquid.

With magnetically-coupled stirrer drives, the product is hermetically encapsulated from the surroundings. The transmission onto the stirrer shaft takes place via a magnetic field, without direct contact.

Magnetic stirrer drives represent the most secure form of shaft sealing to the process side and offers advantages, especially when working with:

- Highly active agents
- Toxic substances
- Very pure materials

All shaft components of the QVF® magnetically-coupled stirrer drive type RAM which are in contact with the process-side are made of corrosion-resistant materials (PTFE, PFA, PEEK). The shaft bearings are sealed from the process side through a radial shaft seal made of PTFE that runs on a PEEK shaft sleeve. The life time of the shaft bearings can also be considerably extended through nitrogen blanketing. Nitrogen is required at an overpressure of 0.1 bar compared to the process side.

For ATEX conformity of nominal diameters exceeding DN50 temperature monitoring is installed using two resistance thermometers

- at the isolating can
- and
- at the shaft seal

Monitoring and processing of the PT100 signals must be realised by the user (can be provided as an option too).

Due to its low peripheral speed, the RAM 50 design is ATEX-compliant even without the temperature measurement at the shaft seal. This has been tested and confirmed in endurance tests.

Technical data for QVF® magnetic coupling of type RAM:

Order no.	Ex category inside/outside		Operating pressure	T _{max} at the isolating can	T _{max} at the shaft seal
			bar	°C	°C
RAM50-3	2G	T4	-1/+3	120	108
RAM80-3	2G	T4	-1/+3	120	108
RAM100-3	2G	T4	-1/+3	120	108
RAM50-3	2G	T3	-1/+3	185	160
RAM80-3	2G	T3	-1/+3	185	160
RAM100-3	2G	T3	-1/+3	185	160

Note:

Suitable for Zone 1 (inside/outside). The maximum permissible conditions for the non-ATEX area correspond to those of temperature class T3.

Sample technical data for complete stirrer drives:

Order no.	Power	Rotation speed	Drive/coupling torque	Motor connection	Motor protection class	Shaft diameter
	KW	1/min	Nm			mm
RAM50/037	0,37	0-600	6/6	230/400V, 50Hz	EEx eII T4	19
RAM80/035	0,5	0-400	6/60	230/400V, 50Hz	EEx eII T4	44,5
RAM80/055	0,55	0-400	12/60	230/400V, 50Hz	EEx eII T4	44,5
RAM100/055	0,55	0-400	12/60	230/400V, 50Hz	EEx eII T4	44,5

Note:

The magnetic-coupling version RAM50-3 is only compatible with a motor of 0.37 kW and a torque of 6 Nm (RAM50/037) due to the limited torque transmission.

The magnetic-coupling types RAM80-3 and RAM100-3 can be combined with all motors from the QVF® product catalogue of De Dietrich Process Systems GmbH (e.g. RAM80/35, RAM80/055, RAM100/055 etc.).